

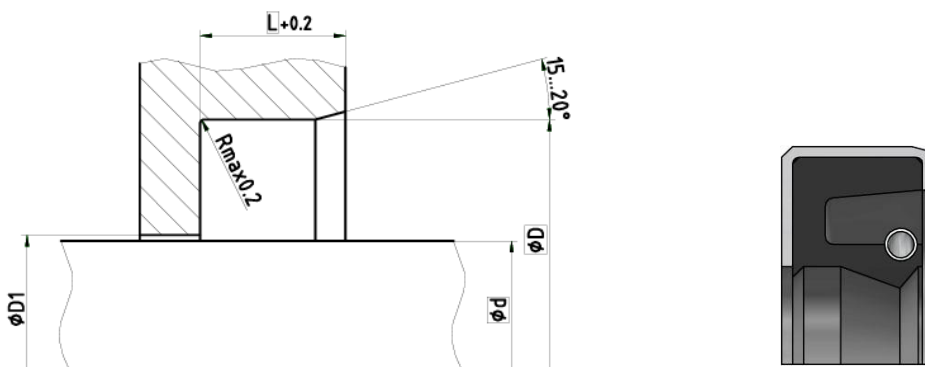

In accordo con la normativa
DIN 7168 [Lavorazioni meccaniche]
According to Normative DIN 7168
[Mechanical Workings]

PROFILO / PROFILE A2

Materiale Material	Temperatura Temperature	Pressione Pressure	Velocità M/s Speed M/s	Dim max Guarnizione Diam max Seal
NBR01	-30°C + 110°C	0.5	10	Da 3 mm A 1500 mm
HN100	-40°C + 151°C		10	Da 3 mm A 1200 mm
EP100	-45°C + 150°C		10	Da 3 mm A 700 mm
FPM01	-20°C + 220°C		10	Da 3 mm A 1200 mm
MVG10	-60°C + 220°C		10	Da 3 mm A 700 mm
PU100-PU110	-30°C + 110°C		5.0	Da 3 mm A 400 mm
CPU01	-30°C + 110°C		5.0	Da 3 mm A 2500 mm
CPU03	-30°C + 110°C		5.0	Da 3 mm A 2500 mm
CPU04-CPU02	-30°C + 110°C		5.0	Da 3 mm A 2500 mm
BPU01	-50°C + 110°C		5.0	Da 3 mm A 600 mm
BAU01	-30°C + 110°C		5.0	Da 3 mm A 1500 mm
APU01	-34°C + 133°C		5.0	DA 3 mm A 1500 mm



Tolleranza sede Housing tolerances		Finiture superficiali Surface finishes	Rtmax µm	Ra µm
d	f8	Fondo sede Bottom of groove	≤ 25.0	≤ 1.6-6.3
D	H8	Stelo Shaft	≤ 6.3	≤ 0.2-0.8
D1	H11			

Stelo / Rod d h11	D H8	L +0.2	R max	L
≥ 5 ≤ 50	d+12	7.30	0.4	7.00
> 50 ≤ 150	d+15	10.30		10.00
> 150 ≤ 250	d+20	10.30		10.00
> 250 ≤ 500	d+30	15.30		15.00
> 500 ≤ 800	d+40	25.30		25.00
> 800 ≤ 1200	d+50	30.30		30.00

Nota: Per facilitare le operazioni di scelta della guarnizione, con il sistema **ALLSEAL** siamo in grado di assistere il progettista nel corretto dimensionamento della guarnizione, proponendo la soluzione più standard.

Please Note: To make the operation easier in choosing the seals with the **ALLSEAL** system, we are able to assist the designer assistant with the correct measurements of the seals, indicating the best solution.