

ZETAEFFE
BUSINESS PARTNER



PTFE Lip Seals

Le tenute rotanti in PTFE sono ormai diffusamente impiegate e hanno in molti casi sostituito i classici elementi di tenuta precedentemente utilizzati.

In molte applicazioni le condizioni operative rendono praticamente inapplicabili le tenute in gomma su alberi in rotazione. Ciò a causa della combinazione di fattori come temperatura, velocità, vibrazioni e prodotti chimicamente aggressivi.

I LIP in PTFE riducono in modo consistente l'attrito e quindi anche l'usura a vantaggio della loro efficienza e durata.

Tutto ciò si traduce inevitabilmente in minori costi di manutenzione e fermi macchina.

Zetaeffe propone i propri LIP Clamped

La nostra gamma dimensionale copre praticamente ogni dimensione.

Fino ad un diametro esterno di 200 mm siamo in grado di produrre i LIP in tempi veramente brevi..

ESECUZIONI STANDARD

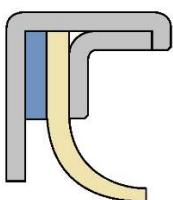

Labbro singolo STD

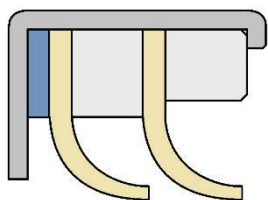

Tandem STD LIP

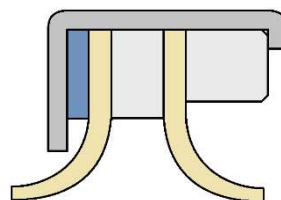

Back to back

Le nostre tenute a labbro in PTFE sono costituite da uno o più elementi di tenuta fissati tra due elementi metallici ribordati ed energizzati assialmente da un elemento elastico.

ESECUZIONI SPECIALI

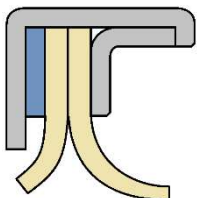

Lip Seal con raschiapolvere

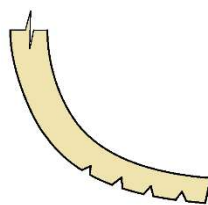

Labbri PL con "Pumping line"

MATERIALI

Parti metalliche in AISI 316L

LIP in PTFE caricati



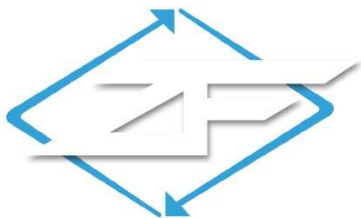

ZETAEFFE

B U S I N E S S P A R T N E R



La combinazione di diversi materiali delle tenute e degli elementi elastici permettono l'impiego LIP praticamente in ogni ambito produttivo.

CONDIZIONI OPERATIVE

Pressione : esecuzione standard 10 bar
 esecuzione speciale 25 bar

Temperatura: -90°C + 250°C

Velocità : fino a 40 m/sec

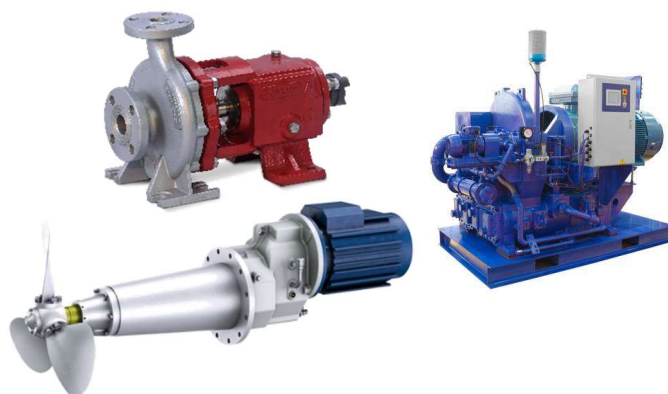

SUPERFICI DI TENUTA

Durezza superficiale : fino a 1,5 bar – minima 45 HRC

 Oltre 1,5 bar – minima 60HRC

Rugosità superficiale ;0,2 Ra ÷ 0,4 Ra

APPLICAZIONI

Separatori, compressori a vite , mixer e agitatori, centrifughe, pompe, giunti rotanti e motori marini.



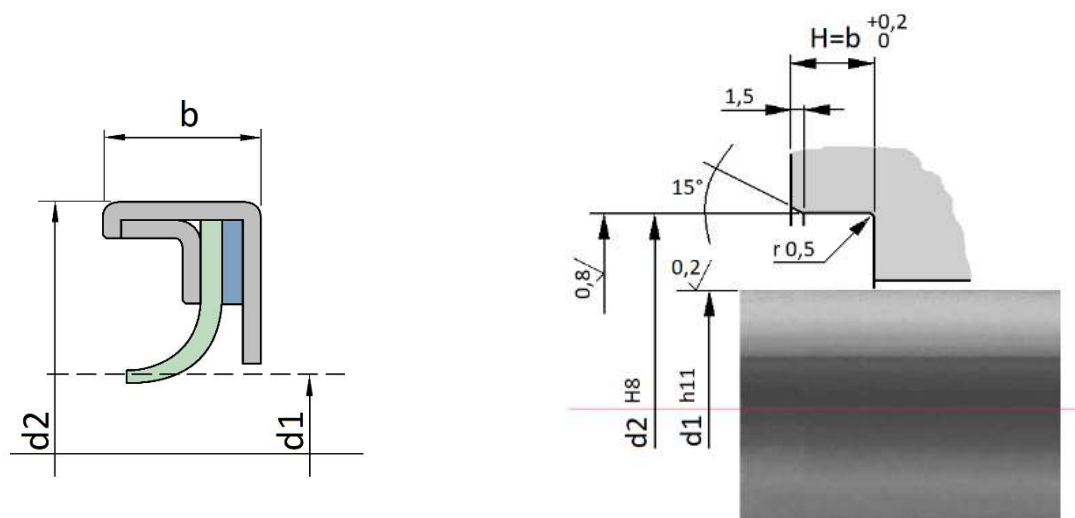
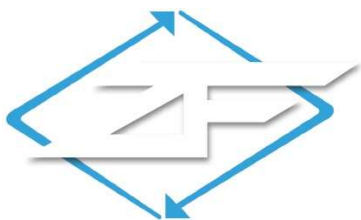

DIMENSIONI STANDARD

d1	d2	b	d1	d2	b
8,0	18,0	5,0	45,0	62,0	10,0
10,0	22,0	6,0	45,0	65,0	10,0
12,0	28,0	8,0	48,0	65,0	10,0
15,0	30,0	8,0	50,0	65,0	10,0
16,0	30,0	8,0	50,0	70,0	10,0
17,0	28,0	8,0	50,0	72,0	10,0
17,0	35,0	8,0	55,0	72,0	10,0
20,0	35,0	8,0	60,0	75,0	8,0
22,0	40,0	8,0	60,0	80,0	10,0
25,0	35,0	8,0	62,0	80,0	10,0
25,0	42,0	8,0	65,0	85,0	10,0
25,0	52,0	7,0	70,0	90,0	10,0
28,0	47,0	10,0	73,0	100,0	10,0
30,0	47,0	10,0	75,0	100,0	10,0
32,0	47,0	8,0	75,0	95,0	13,0
32,0	47,0	10,0	80,0	100,0	10,0
35,0	47,0	8,0	85,0	120,0	12,7
35,0	50,0	10,0	90,0	110,0	10,0
38,1	63,5	12,7	95,0	120,0	12,0
40,0	55,0	10,0	100,0	130,0	13,0
40,0	60,0	10,0	110,0	140,0	13,0
40,0	62,0	10,0	120,0	150,0	12,0
40,0	68,0	10,0	140,0	165,0	10,0
42,0	62,0	8,0	150,0	180,0	12,0
42,0	60,0	10,0	160,0	190,0	12,0

Per dimensioni diverse da quelle indicate , contattare il nostro ufficio tecnico.



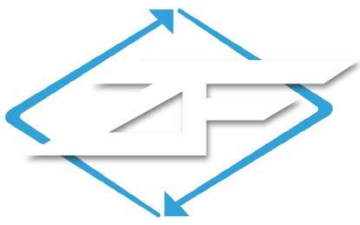

ZETAEFFE
BUSINESS PARTNER

